

The Newland Glassveyor allows sealed double glazed units to cure as they travel along the conveyor from the bonding process to the despatch vehicle.

Slats are manufactured from specially formed plated steel with integral plastic bearers for the glass. Removable wooden dowels fitted to the slats support the glazed units in an upright position. Slow speed together with soft start and stop features, prevent sharp movement, eliminating product breakage.

Glassveyor



Trucklift

The Trucklift is a robust moveable tail lift platform for loading or unloading hand trucks and roll pallets.

The side mounted lifting gear means the operator has only to push the load up on to a platform 56mm high.

Bridging plates are fitted at either end of the platform to allow goods to be wheeled directly into or out of the vehicle.

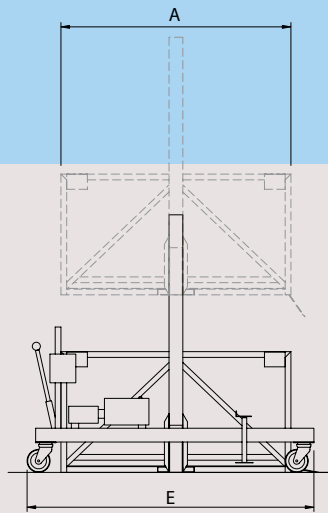
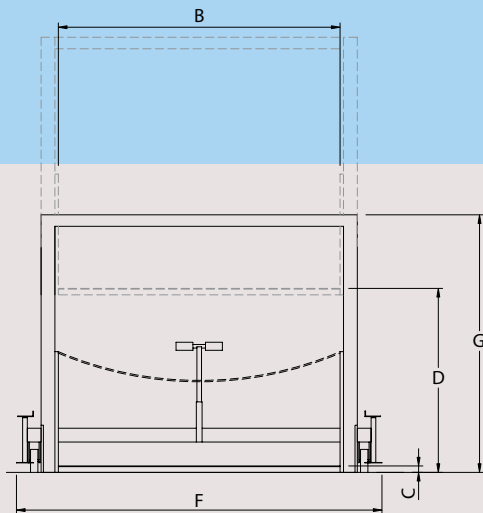

General Dimensions (mm) (Alternative machine dimensions also available)

	1 PALLET - 2 CAGE	2 PALLET - 4 CAGE	4 PALLET - 6 CAGE
PLATFORM DEPTH (A)	1850	2000	2550
PLATFORM WIDTH (B)	1500	2450	2450
LOWERED HEIGHT (C)	2000KG LIFT 56	56	56
	3000KG LIFT 56	56	56
	DRIVE THROUGH MODEL 106	106	106
ELEVATED HEIGHT (D)	1600	1600	1600
OVERALL LENGTH +200 (E)	2070	2220	2770
OVERALL WIDTH (F)	2240	3190	3190
OVERALL HEIGHT (G)	2240	2240	2240

Speed of elevation: 2000kg lift - 85mm/sec
3000kg lift - 50mm/sec.